

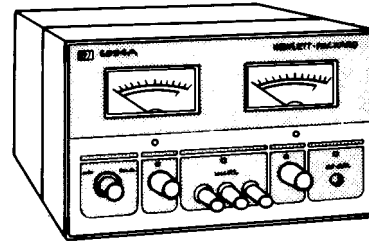

Agilent AN 250-2

Lab & Industrial Power Sources

Application Note



Battery Charging/Discharging

Introduction:

The charging and discharging of batteries has become an area of careful study in the aerospace and automotive industries as well as many others. Precise control of the charging and discharging characteristics of batteries may be necessary in applications ranging from satellite design to battery development and evaluation.

Although sufficient for many consumer applications, the comparatively poor charging characteristics of readily available “battery chargers” may not provide the precision necessary in many critical applications. To achieve a high degree of accuracy, stability, and regulation, the DC power supply approach can be utilized. Battery discharging may be accomplished with these same DC power supplies with little or no modification to the basic unit.

Several different types of battery charging and discharging techniques using Agilent Technologies DC power supplies will be examined in this application note.

Charge Methods:

One of the most commonly used approaches to charging batteries is the “constant current method” sometimes referred to as a “slow charge” method. This name arises from the fact that it typically requires 14-16 hours to fully charge an Ni-Cd cell. The charge rate for this method is typically $0.1C$, where C is the nominal ampere-hour rating of the cell. At this charge rate, standard nickel-cadmium sealed cells can tolerate an overcharge for extended periods of time without damage or serious performance degradation.

The other charging method that will be discussed is the “taper charge” method. When charging

lead-acid cells, many manufacturers recommend that the charging current be reduced as the charge nears completion. This *taper charge* can be accomplished by inserting a small resistance in series with one of the load leads between the power supply and the battery being charged.

Constant Current Charging:

The automatic crossover between constant voltage and constant current exhibited by most Agilent power supplies make them ideal for battery charging applications. Using this feature, a battery may be charged at a constant current until the maximum charge voltage is reached, at which point the supply will revert to constant voltage and continue to supply a trickle charge current sufficient to maintain full charge. (See Figure 1.) Thus, the charging operation can be unattended after properly setting the charging rate and the maximum charge voltage, then connecting the battery to the output terminals of the power supply.

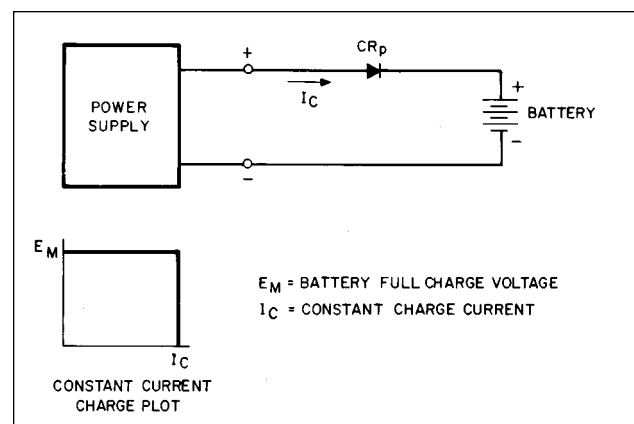

Figure 1. Constant Current Charging



Agilent Technologies

Innovating the HP Way

Protection diode CRp prevents a charged battery from discharging into and damaging a supply if the supply is turned off. The diode should be capable of withstanding currents as high as I_C .

Constant Current Charging Procedure

The procedure for setting the charging rate and full charge voltage on constant voltage/constant current power supplies is as follows:

- Turn both the VOLTAGE and CURRENT controls fully counter clockwise (CCW).
- Place a short circuit across the output terminals of the supply and rotate the VOLTAGE control fully clockwise (CW).
- Rotate the CURRENT control to the desired charging rate as read on the front panel ammeter.
- Rotate the VOLTAGE control fully CCW and remove the short circuit.
- Rotate the VOLTAGE control to the desired full charge voltage as read on either the front panel voltmeter or a more precise DVM. Remember to set the voltage 0.7 volts more than the required full charge voltage to compensate for the drop across diode CRp. The unit may then be connected to the battery terminals (positive to positive and negative to negative).

Taper Charging:

In taper charging the charge current is reduced as the battery nears completion of its charge. The taper charge is accomplished with the addition of a small resistance (R_T). The value of this resistance is the difference between the full charge voltage (E_M) and the voltage at which the tapering is to start (E_T), divided by the maximum charging current (I_C). The current charging plot and the connection diagram for taper charging are shown in Figure 2. Follow the same procedure for taper charging as for constant current charging.

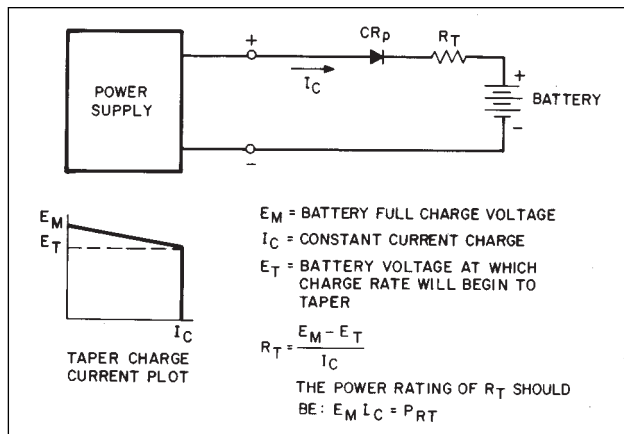

Figure 2. Taper Charging

Battery Discharging:

Agilent constant voltage/constant current DC power supplies are also useful when batteries must be discharged at a constant current. Connecting the supply as shown in Figure 3 and following the "battery discharging" instructions makes unattended constant-current discharge possible. Using this procedure, the power supply output will automatically shut-off when the battery voltage reaches zero; thus, preventing reverse charging of the battery.

The Power Supply operates in the constant current mode, delivering an output current which is established by the front panel current control. The constant current (I_D) delivered by the supply forces the battery to be discharged. The discharge rate, in ampere-hours, is determined by I_D . The constant current flowing through dropping resistor R_x produces a constant voltage across the resistor. Resistor R_x is selected such that its IR drop is larger than the initial battery voltage (E_B). This prevents the supply from sinking any current by keeping the output voltage positive. The minimum output voltage from the supply will be $(I_D R_x) - E_B$. Initially, the battery voltage is high and the supply's output voltage is low, but as the battery voltage decreases during discharge, the supply voltage increases. When the battery voltage reaches zero, the supply senses this through the connection to its voltage comparator summing junction and reduces the output current to zero. If the automatic shut-off feature is

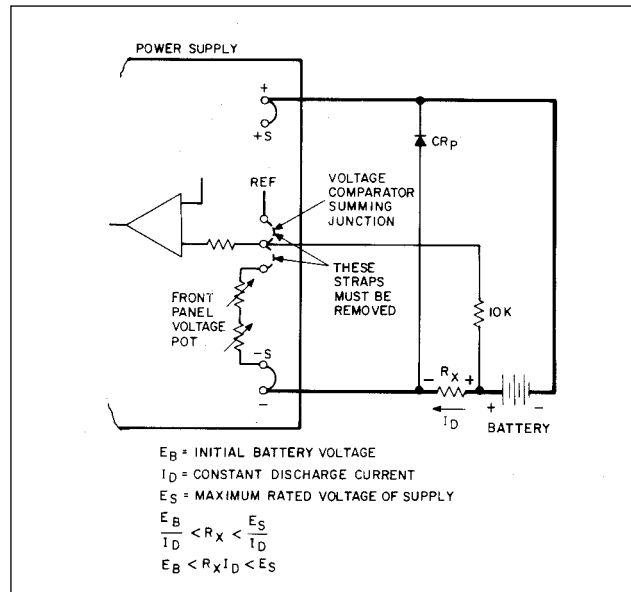

Figure 3. Constant Current Discharge

not required, the 10 kilohm resistor may be omitted, and the jumper straps connecting the voltage comparator summing junction to the reference supply and front panel voltage potentiometers should be replaced. As shown in Figure 3, R_x must be selected such that its IR drop is less than the maximum rated output voltage of the supply, but greater than the initial battery voltage.

Diode CRp is included to protect the supply against reverse voltage. The diode should be capable of withstanding currents as high as E_B/R_x .

Battery Discharging Procedure. The procedure for the connection of the components in Figure 3 is as follows:

- a. Turn off the power supply and turn the CURRENT control fully CCW. (The VOLTAGE control will be disconnected by step b.)
 - * b. Remove the jumpers connected to the summing junction and connect the summing point to the positive terminal of the battery through the 10 kilohm resistor.
 - c. Connect the positive terminal of the supply to the negative terminal of the battery.
 - d. Insert R_x between the negative terminal of the supply and the positive terminal of the battery, energize the supply, and turn the current control to the desired discharge current as read on the front panel meters.
- * NOTE: If the automatic shut-off feature is not desired skip step b.

Conclusion

This application note will provide the necessary information for most battery charging and discharging applications. If the power supply and components to be used are carefully chosen, the results should be more than satisfactory. The connection diagrams illustrated in this application note are typical. To ensure proper operation use the exact connections as illustrated in the operating and service manual for the power supply being used.

By internet, phone, or fax, get assistance with all your test and measurement needs.

Online Assistance

www.agilent.com/find/assist

Phone or Fax

United States:
(tel) 1 800 452 4844

Canada:
(tel) 1 877 894 4414
(fax) (905) 206 4120

Europe:
(tel) (31 20) 547 2323
(fax) (31 20) 547 2390

Japan:
(tel) (81) 426 56 7832
(fax) (81) 426 56 7840

Latin America:
(tel) (305) 269 7500
(fax) (305) 269 7599

Australia:
(tel) 1 800 629 485
(fax) (61 3) 9210 5947

New Zealand:
(tel) 0 800 738 378
(fax) (64 4) 495 8950

Asia Pacific:
(tel) (852) 3197 7777
(fax) (852) 2506 9284

Product specifications and descriptions in this document subject to change without notice.

Copyright © 1999, 2000 Agilent Technologies
Printed in U.S.A. 9/00
5952-4033



Agilent Technologies

Innovating the HP Way